

# Load Cell Accuracy in Relation to the Conditions of Use

## 1. Load Cell Accuracy

Load cells are ranked, according to their overall performance capabilities, into differing accuracy classes or grades. A specific accuracy grade specifies an error envelope for certain parameters, such as linearity, hysteresis, temperature effects, creep, etc.

In practice, certain system accuracy parameters depend considerably on the application of use, physical load introduction to the transducer and disturbing factors such as Zener barriers and surge protection devices.

This technical paper will cover load cell accuracy grades according to the OIML and NTEP standards, and their compatibility when used in legal for trade weighing instruments. It will also cover key terminology and metrological terms which are used by load cell and scale manufacturers, as well as Weights and Measures Authorities.

In addition to this, the article will focus on those conditions of load cell use that either compromise, or enhance the actual scale performance.

### 1.1 United States

In the United States, guidelines for legal for trade weighing instruments are laid down in handbook 44 of the National Institute of Standards and Technology (NIST). The evaluation of critical metrology equipment and components, including load cells, is formalized by the National Type Evaluation Program (NTEP).

NTEP Class III covers most commercial weighing applications for systems which have between 500 and 10,000 scale divisions. Class IIIIL specifically covers larger capacity applications such as vehicle, axle-load, livestock, crane and railway track scales as well as hopper scales (other than grain hopper) which have between 2000 and 10,000 divisions. Each of these classes can be further subdivided into Single and Multiple, depending on whether one or more load cells are used in a particular system.

The load cell error tolerance for Single is set at 0.7 times the scale divisions, while Multiple is set at 1.0 times the scale divisions.

## 1.2 Europe/Worldwide

In Europe, guidelines for legal for trade weighing systems have been treated differently in different countries. In order to harmonize and standardize on an international basis, a convention was held in Paris on October 12<sup>th</sup>, 1955, and the participating States (countries) agreed to set up an **International Organization of Legal Metrology**.

Because the official language was French, the name of the organization is Organization Internationale de Metrologie Legale.

OIML Recommendations and Documents relate to specific measuring instruments and technology. International Recommendations (OIML R) are model regulations generally establishing the metrological characteristics required of the measuring instruments concerned and specifying methods and equipment for checking their conformity. OIML member states are expected to implement these Recommendations as far as possible.

OIML class III covers the commercial weighing applications between 500 and 10,000 divisions. The OIML does not recognize the difference between Single and Multiple cell applications, but it accepts and utilizes the concept in the apportionment of errors (OIML R76). Load cells are tested and certified according to OIML R60. The load cell error tolerance is set at 0.7 times the scale division.

VPG Transducers manufactures products meeting NTEP, OIML and in-house specifications. Depending upon the standard and the performance of a particular load cell type, an alphanumeric "accuracy grade" is given to the product. The alpha designate refers to the specific accuracy class, while the numeric part refers to the number of divisions:

- Az Products meet the NTEP requirements for class III applications.
- Bz Products meet the NTEP requirements for class IIIIL applications.
- Cz Products meet the OIML requirements for class III and IIIIL applications.

Note: "z" represents the number of divisions (x1000), i.e. A3, B10, C6, etc.

## Load Cell Accuracy in Relation to the Conditions of Use

### 1.3 Accuracy Related Terms

**Accuracy class:**

A class of load cells which are subjected to the same conditions of accuracy. A load cell is classified by the alphabetical classification and the maximum number of load cell intervals stated in units of 1000.

**Load cell verification interval:**

The load cell interval ( $v$ ), expressed in units of mass, used in the test of the load cell for accuracy classification.

**Number of verification intervals:**

The number of verification intervals ( $n$ ), used in the test of the load cell for accuracy classification.

**Non-linearity:**

The deviation of the increasing load cell calibration curve from either:

- 1) a straight line which passes through minimum load output and the load cell output at 75% of the measuring range (OIML load cell verification).
- 2) a straight line connecting the zero load and the rated load output values (scales).
- 3) the best straight line fitted to output values by the least squares method, through zero load output.

All measurements at a stable ambient temperature of 20°C or 68°F.

**Hysteresis:**

The difference between load cell output readings for the same applied load, one reading obtained by increasing the load from minimum load and the other by decreasing the load from maximum load.

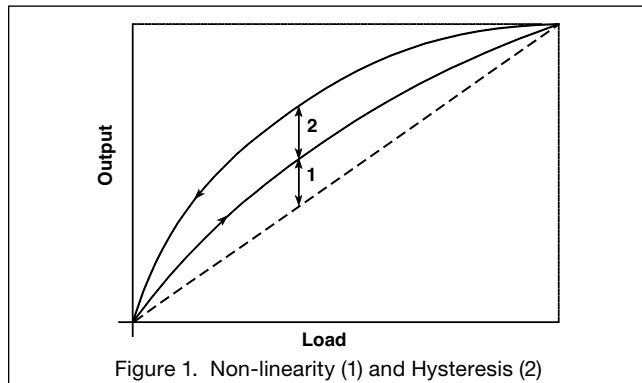

**Creep:**

The change in load cell output occurring with time while under constant load (>90% of the load cell capacity) and with all environmental conditions and other variables remaining constant.

OIML recommendation R76 requires a 30 minute test and specifies an error limit for this time period, as well as the last 10 minutes (20 to 30 minutes). NTEP requires a one hour test and specifies an error limit for this period.

**Minimum Dead Load Output Return (MDLOR):**

The difference in load cell output at minimum dead load, measured before and after a 30 minute load application of at least 90% of the cell's rated capacity (OIML only).

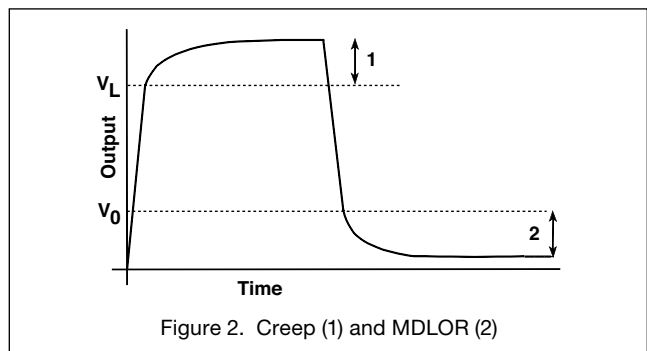

**Temperature effect on minimum dead load output:**

The change in minimum dead load output due to a change in ambient temperature.

**Temperature effect on sensitivity:**

The change in sensitivity due to a change in ambient temperature.

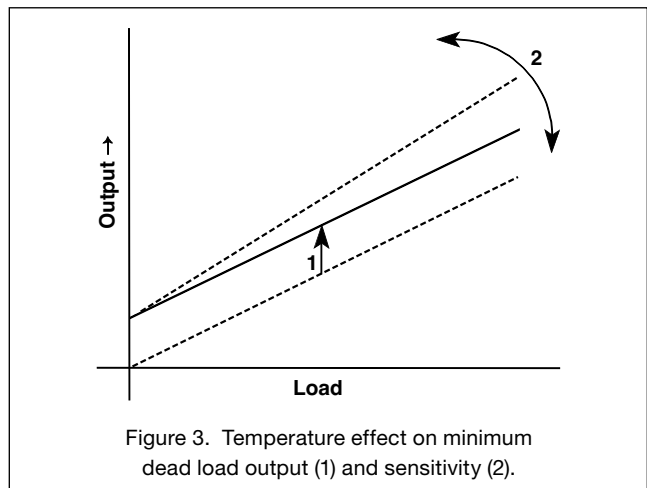

**Combined error:**

The total error envelope allowed for a load cell as the limiting factor. The approach taken by NTEP and OIML recognizes that several errors must be considered together when fitting performance characteristics to the error envelope permitted.

APPLICATION NOTE

## Load Cell Accuracy in Relation to the Conditions of Use

It is not considered appropriate to specify individual error limits for given characteristics (non-linearity, hysteresis and temperature effect on sensitivity).

The use of an error envelope or combined error concept allows balancing individual factors to the total error of measurement while still achieving the intended results.

### Minimum verification interval ( $v_{min}$ ):

Most weighing systems use load cells where their working or measuring range is well below their rated capacity. In these situations, the values for the load cell utilisation and minimum verification interval ( $v_{min}$ ) are important.

The minimum verification interval is defined as the smallest value of a quantity (mass) which may be applied to a load cell without exceeding the maximum permissible error. It is specified as  $E_{max}/\gamma$ , where  $E_{max}$  represents the load cell's rated capacity and  $\gamma$  represents a value which is specified by the load cell supplier.

The minimum verification interval is inextricably linked to the utilization of the load cell. The utilization can be defined as the minimum measuring range (MMR) for a particular load cell over which full specification will be maintained. The following formulas can be applied:

$$MMR(\%) = n_{max} * 100 / \gamma$$

or

$$MMR(kg/lbs) = v_{min} * n_{max}$$

For example an SSB-1t-C3 load cell, with  $v_{min}=E_{max}/10000$  has a minimum measuring range of

$$1000 * 3000 / 10000 = 300 \text{ kg}$$

or

$$3000 * 100 / 10000 = 30\%$$

The minimum measuring range can apply over any part of the measuring range between zero load and the load cell's rated capacity. The above calculation applies to a single cell application.

### 1.4 Load Related Terms

#### Minimum dead load ( $E_{min}$ ):

The smallest value of a quantity (mass) which may be applied to a load cell without exceeding the maximum permissible error.

#### Maximum capacity ( $E_{max}$ ):

The largest value of a quantity (mass) which may be applied to a load cell without exceeding the maximum permissible error.

#### Load cell measuring range:

The range of values of the measured quantity for which the result of measurement should not be affected by an error exceeding the maximum permissible error.

#### Safe load limit:

The maximum load that can be applied without producing a permanent shift in the performance characteristics beyond those specified.

#### Ultimate load limit:

The maximum load that can be applied without physical destruction of the load cell. Specified as a percentage of  $E_{max}$ .

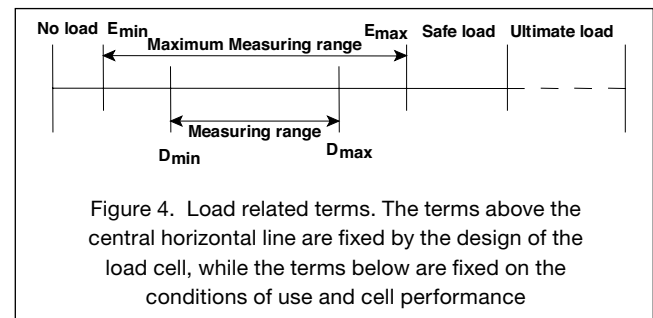

Figure 4. Load related terms. The terms above the central horizontal line are fixed by the design of the load cell, while the terms below are fixed on the conditions of use and cell performance

### 1.5 Single Internal Systems

Legal for trade single interval weighing systems require load cells which are certified according to the National Type Evaluation Program (NTEP) or OIML recommendation R60 (Europe). The requirements in terms of load cell accuracy for the above mentioned systems are:

- 1) Select a cell which is certified according to the appropriate standard, i.e. products designated "Cz" for class III applications.
- 2) For each load cell, the maximum number of load cell intervals shall not be less than the number of verification scale intervals. For example; a 3000 division class III scale requires C3 load cells.
- 3) The minimum load cell verification interval shall satisfy the condition:

$$v_{min} \leq e * R / \sqrt{N}$$

where  $e$  represents the scale verification interval and  $R$  represents the reduction ratio of the load transmitting device (hybrid scales).

$$R = \text{Load acting on the load cells} / \text{Load acting}$$

For example:

A fully electronic scale ( $R = 1$ ), with four load cells and a measuring range of 1500 kg divided into 3000 divisions requires load cells with the following  $v_{min}$ :

## Load Cell Accuracy in Relation to the Conditions of Use

$$v_{min} \leq (1500 / 3000) * (1 / \sqrt{4}), \text{ i.e. } v_{min} \leq 0.25 \text{ kg}$$

Note: The output per scale division ( $\mu V/d$ ) needs to be verified to ensure compatibility with the indicator.

### 1.6 Maximum Permissible Errors

Table 1 represents the combined error envelope for load cells and systems while table 2 represents the load cell requirements for the other performance characteristics: repeatability, creep, MDLOR and temperature effect on minimum dead load output.

The differences between A, B, and C class load cells becomes apparent when the combined error envelopes or tolerance bands are compared.

However, to get a clear comparison it is important to compare them in absolute terms, rather than in terms of load cell divisions. Figure five represents the error envelope graphs for a sample load cell with a capacity of 30,000 weight units (lbs/kg).

NTEP Class III Single falls in line with OIML; however an additional tolerance step at 4000d is permissible for A5 compared to C5.

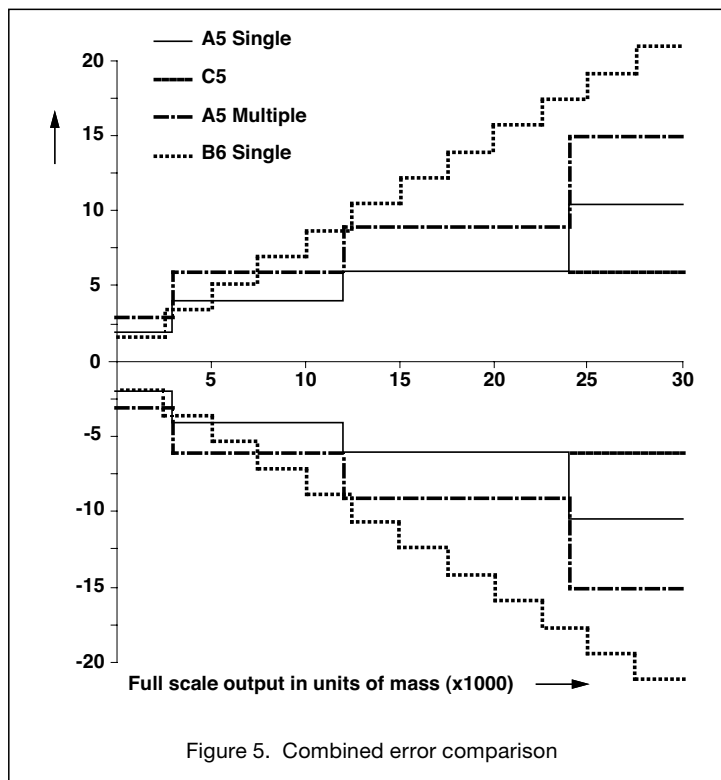

Table 1: Combined error envelope for load cells and systems

Class	Divisions	Weighing Machine NIST H44	Weighing Machine OIML R76	Load Cell NIST H44 Single	Load Cell NIST H44 Multiple	Load Cell OIML R60
III	0 - 500	0.5d	0.5d	0.35v	0.5v	0.35v
	501 - 2000	1.0d	1.0d	0.7v	1.0v	0.7v
	2001 - 4000	1.5d	1.5d	1.05v	1.5v	1.05v
	4001 - 10000	2.5d		1.75v	2.5v	
IIIL	0 - 500	0.5d	N/A	0.35v	0.5v	N/A
	501 - 10000	+0.5d/500d		+0.35v/500d	+0.5v/500d	

APPLICATION NOTE

## Load Cell Accuracy in Relation to the Conditions of Use

Table 2: Repeatatability, creep, MDLOR and temperature effect on MDLO

	Verification Intervals (Load)	NTEP CLASS III L		Verification Intervals (Load)	NTEP CLASS III L		OIML Class C
		Single	Multiple		Single	Multiple	
Repeatability	0 - 500v	0.70v	1.00v	0 - 500v	0.70v	1.00v	0.35v
	501 - 1000v	1.40v	2.00v	501- 2000v	1.40v	2.00v	0.70v
	+500v	+0.70v	+1.0v	2001 - 4000v	2.10v	3.00v	1.05v
	9501 - 10000v	14.0v	20.0v	4001 - 10000v	3.50v	5.00v	
Creep (*)	0 - 500v	0.25v	0.25v	0 - 500v	0.50v	0.50v	0.245v
	501 - 1000v	0.50v	0.50v	501- 2000v	1.00v	1.00v	0.490v
	+500v	+0.25v	+0.25v	2001 - 4000v	1.50v	1.50v	0.735v
	9501 - 10000v	5.00v	5.00v	4001 - 10000v	2.50v	2.50v	0.50v
Minimum dead load output return (OIML R60 only)	N/A			0 - 500v	N/A		0.50v
	N/A			501- 2000v	N/A		
	N/A			2001 - 10000v	N/A		
	N/A				N/A		
Temperature effect on minimum dead load output	2.1 $v_{min}/5^{\circ}\text{C}$			0.7 $v_{min}/5^{\circ}\text{C}$			

(\*) NTEP Class III L and III; test at 90 - 100% of rated capacity for one hour. OIML R60 Class C; test at 90 - 100% of rated capacity for half an hour, 0.15 \* maximum permissible error between 20 and 30 minutes.

### 2. Conditions of Use

Load cells are ranked into differing accuracy classes based on their performance in pre-described tests, with specified equipment. In almost all cases tests are performed with optimal load introduction to the transducer, at stable ambient temperatures.

But actual load cell performance in any weighing instrument depends considerably on the conditions of use. Disturbing factors may include load cell utilisation, temperature gradients, eccentric load introduction, torque on fixing bolts for beams, Zener barriers, surge protection devices, stiffness of the support structure, etc.

#### 2.1 Load Cell Utilization

The load cell measuring range (MR) is defined as that range in which the result of measurement is not affected by an error exceeding the maximum permissible error. The following expression can be used:

$$MR = E_{max} - E_{min} = n * v$$

where, "n" represents the number of verification intervals and "v" represents the load cell verification interval, expressed in units of mass.

Most weighing systems use load cells where their measuring range is well below their rated capacity. The minimum measuring range can be calculated by:

$$MMR = v_{min} * n$$

where,  $v_{min}$  represents the minimum verification interval, specified by the load cell supplier. The minimum measuring range can apply over any part of the measuring range between zero load and the load cell's rated capacity.

The maximum load on the transducer ( $D_{max}$ ) can be calculated by:

$$D_{max} = (v_{min} * n) + D_{min}$$

where,  $D_{min}$  represents the contribution of the system dead load.

#### 2.1.1 Linearity and Hysteresis

In general, linearity and hysteresis will improve when a smaller part of the measuring range is used. The improvement depends primarily on the initial performance for both characteristics and on the actual measuring range of the transducer ( $v_a * n$ ).

## Load Cell Accuracy in Relation to the Conditions of Use

Figure 6 represents the combined error performance of a sample load cell with a rated capacity of 500 kg. The cell has been measured with a utilisation of 20% (1), 40% (2), 60% (3) and 80% (4) of the rated capacity.

By reducing from 80 to 20% utilisation, the non-linearity has improved by a factor of 7, while the hysteresis has improved by a factor of 8!

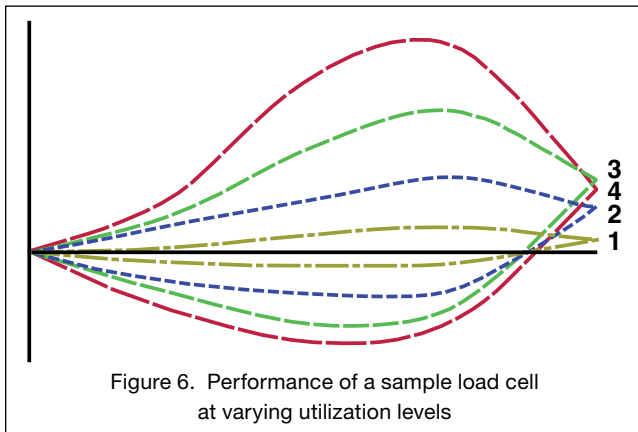

Figure 6. Performance of a sample load cell at varying utilization levels

### 2.1.2 Creep and MDLOR

The effect of utilization on creep will depend on which part of the measuring range is being used for the scale; creep will be more significant in a scale where its working range is at the top end of the load cell's rated capacity than when it is at the bottom.

Extensive tests have shown that the following formula can be used to predict approximate load cell performance:

$$y = (D_{max} / E_{max}) * x$$

where, "x" represents the performance on creep or MDLOR measured over the load cell's full measuring range, and "y" represents the improved performance when the load does not exceed  $D_{max}$ .

**APPLICATION NOTE** It is important to recognise that the system dead load contributes directly to the maximum load on the transducer ( $D_{max}$ ) and as such influences the performance improvement which may be achieved. This is not applicable for improvements which may be achieved on linearity and hysteresis.

### 2.1.3 Restrictions / Considerations

The temperature effect on zero load output or sensitivity is a fixed error percentage of the load cell output at a certain utilization. These characteristics will therefore not improve when load cells are used over a part of their measuring range. The minimum verification interval is directly related to the temperature effect at zero load.

In general, the overall accuracy of a weighing system will improve when load cells are used over a (smaller) part of their measuring range. In addition to this the system will be stronger in terms of load cell overload risk.

The output per scale division should be verified against the required minimum signal level for the measuring device or indicator. Smaller signals are also more susceptible to noise (electromagnetic interference) or temperature effects on extension cables and additional hardware (balancing resistors, barriers, etc.).

## 2.2 Load Introduction

Load cells are tested and ranked while being loaded under optimum conditions. Normally it will be extremely difficult (if not impossible) to reproduce these conditions when load cells are used in practical applications. As a result the initial load cell accuracy and repeatability may be compromised to such an extent where scale performance is no longer acceptable.

Load cell performance may be compromised by lateral forces, bending moments, torsion moments or off centre loading. The following terms are used to describe loading conditions:

#### Principal axis

The axis along which the load cell is designed to be loaded.

#### Axial load

Load applied along the principal axis of the load cell (correct loading).

#### Eccentric load

A load applied parallel to the principal axis at a specified location and eccentricity.

#### Inclined load, concentric

A load applied through the principal axis of the load cell at the point of load application, inclined at an angle and at a defined direction with respect to the principal axis.

#### Inclined load, eccentric

A load applied eccentric to the principal axis of the load cell at the point of load application, inclined at an angle and at a defined direction with respect to the principal axis.

#### Side load

A load acting at a 90 degree angle to the principal axis of the load cell on the specified loading surface and in a defined direction.



## Load Cell Accuracy in Relation to the Conditions of Use

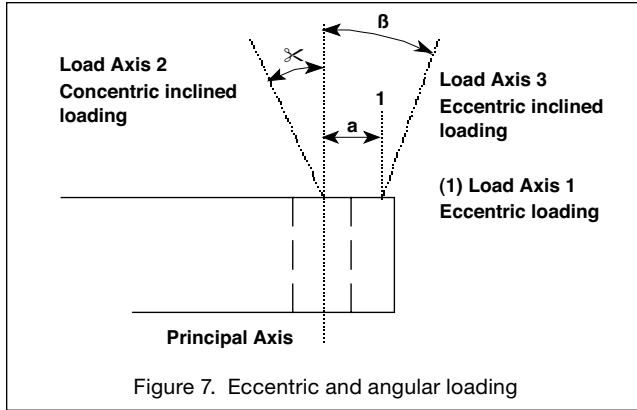

Figure 7. Eccentric and angular loading

### 2.2.1 Concentric Loading

The effect of concentric loading can be determined by the use of wedge shaped pads above and below the load cell. Eight measurements at intervals of 45° should be taken to find the maximum error which should be specified. The error value at each position can be calculated by:

$$e_1 = [(S_r - S_e / \cos\alpha) / S_r] * 100\%$$

where,  $S_e$  represents the average rated output and  $S_a$  represents the average rated output under concentric loading conditions.

The formula above compensates for the fact that the applied force  $L_a$  under angle  $\alpha$  will have a vertical component  $L_p$ .  $L_p$  can be calculated by:

$$L_p = \cos\alpha * L_a$$

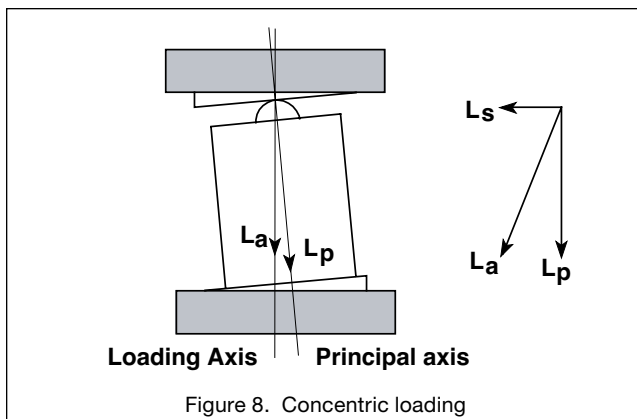

Figure 8. Concentric loading

*Inclined loading effects should be considered for compression type cells only. Because of bending effects in the column, single column load cells are more sensitive than multiple column cells.*

*The effect on beam type load cells is usually very small and can be partly compensated for in the calibration of the weighing instrument.*

### 2.2.2 Eccentric Loading

The effect of eccentric loading can be determined by applying a load, displaced at a distance "a" from the principal axis. Eight measurements at intervals of 45° should be taken to find the maximum error which should be specified.

The error, as a percentage of the rated output, at each angular position can be calculated by:

$$e_1 = (S_r - S_e / S_r) * 100\%$$

where,  $S_e$  represents the average rated output while the cell is being loaded eccentrically.

Enhanced scale performance is offered when load cell orientation in a system is based on a model specific eccentric loading diagram (figure 9). This diagram represents the typical error experienced when a load cell is eccentrically loaded in a defined direction.

A typical eccentric loading diagram can only be provided when load cells are produced with highly consistent manufacturing processes.

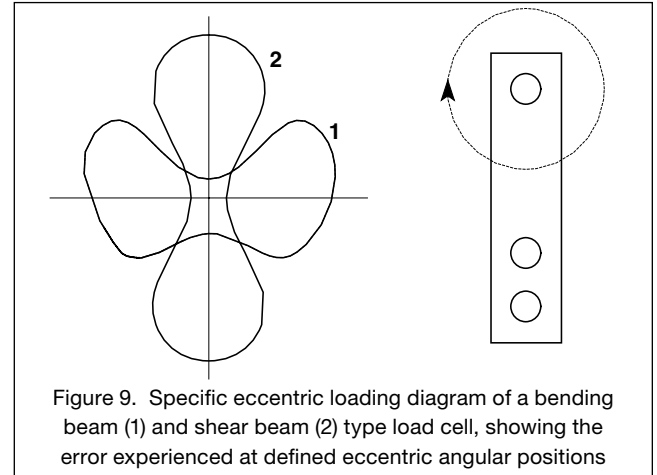

Figure 9. Specific eccentric loading diagram of a bending beam (1) and shear beam (2) type load cell, showing the error experienced at defined eccentric angular positions

### 2.2.3 Summary

Load cell performance may be compromised by a variety of disturbing factors such as concentric angular loading, eccentric loading, side loading, etc.

Loading effects can be reduced not only with suitable load introduction devices or mounts but also with optimum scale design, based on information provided by the load cell manufacturer.

### 2.3 Temperature Gradients

The measuring principle of any strain gage load cell is based on a spring or so called sensing element which

## Load Cell Accuracy in Relation to the Conditions of Use

deflects repeatable when loaded. Strain gages are used to identify strain in the element in terms of a resistance change. This change in resistance can then be converted into a usable electrical signal by connecting the four strain gages (or a multiple of four) in a Wheatstone bridge configuration. The raw output of the Wheatstone bridge needs further compensation in order to offer a calibrated, temperature stable signal.

Sensing elements can be made of tool steel (nickel plated for protection against corrosion), stainless steel, aluminium or a copper-beryllium alloy. All these materials respond to temperature changes with a non-linear length increase (the elasticity modulus of steel varies with temperature).

In general, two mechanisms are used to compensate for the above mentioned temperature effects. Firstly, a temperature dependant wire is connected into the Wheatstone bridge to compensate the offset for non-homogeneous changes in component resistance and steel elasticity. Secondly, so called modulus resistors are connected in the excitation lines to compensate the span for a varying elasticity modulus at varying temperatures. Modulus resistors are usually made like a strain gage and are also glued to the element in order respond rapidly to any change of temperature.

The temperature compensation system of load cells provides consistent output readings when the load cell is stabilized at varying temperatures.

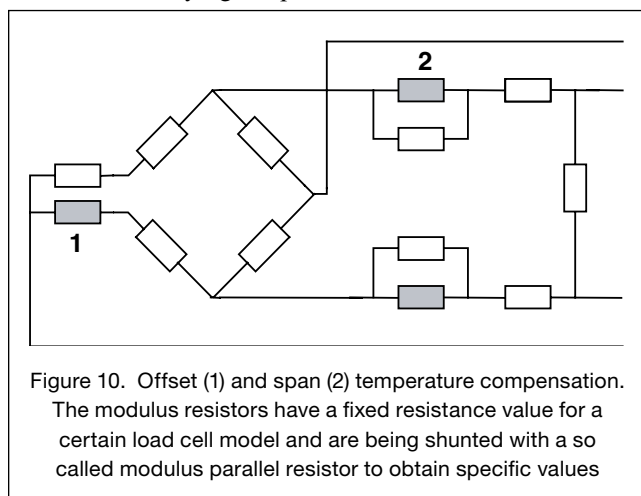

Figure 10. Offset (1) and span (2) temperature compensation. The modulus resistors have a fixed resistance value for a certain load cell model and are being shunted with a so called modulus parallel resistor to obtain specific values

Dynamic temperature changes may induce errors which far exceed the allowed limits. The magnitude of these errors depends not only on the load cell design itself and on the location of the strain gages and modulus resistors, but also on the element size and measuring principle.

Canister load cells are far more susceptible to dynamic temperature changes than beam load cells. When used in

outdoor applications, appropriate screens against direct sunlight should be used at all times.

Temperature gradients may also be caused in process applications where load cells support heated vessels or containers. Insulation pads between load cells and the vessel should be used to minimise errors. In addition to this load cells with a relatively fast temperature settling time should be selected. Temperature settling times generally vary from 1 hour per 10°C/18°F for small compact beams to 5 hours per 10°C/18°F or more for canisters. Load cell suppliers should be encouraged to specify this important characteristic.

### 2.4 Load Cell Deflection

Load cells are often considered as a solid piece of steel on which platforms, vessels, etc can be supported. The performance of a load cell depends primarily on its ability to deflect under highly repeatable conditions when load is applied or removed. From an accuracy point of view, a weighing system should be free from its surroundings. However, in most process applications a contact between the weighing system and its surroundings is present. Examples are: pneumatic/hydraulic hoses, electrical cables, pipes, bellows and constrainers. If the influence of external connections to the weighing instrument is not constant, non-repeatability, hysteresis and span errors will be introduced.

Perhaps the most common and easiest to understand system is a vessel restrained by stay rods.

Stay rods are used if major load movement is anticipated, for example in weighbridges or vessels with an agitator. Stay rods are installed horizontally and should not transfer any forces to the vessel or platform. However, because of the inherent load cell deflection, errors are unavoidable. The following expression could be used to calculate the vertical component of a side force:

$$F_p = F_s * d / l$$

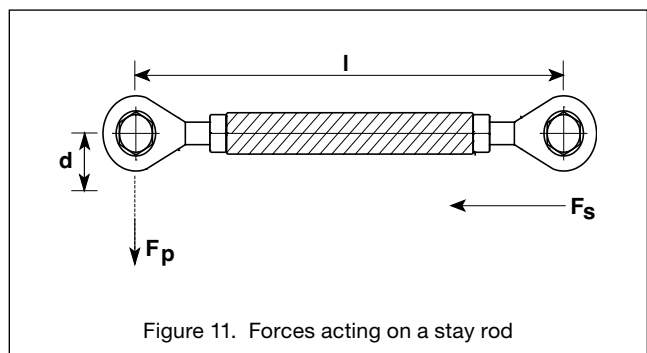

Figure 11. Forces acting on a stay rod



## Load Cell Accuracy in Relation to the Conditions of Use

where,  $F_p$  represents the vertical component along the principal axis of the load cell,  $F_s$  represents the side force and  $d$  represents the load cell deflection.

The formula shows that errors can be reduced by selecting the length of the stay rod to be as long as possible, or by selecting load cells with a low deflection.

The horizontal force  $F_s$  on the stay rod may vary at any time, causing an undefined span error which can not be compensated for at system calibration!

### 2.5 Zener Barriers and SPDs

Zener barriers are frequently used in systems which are installed in hazardous areas. The barrier acts as a safety device which limits the energy that may be transferred to the hazardous area under fault conditions.

Surge protection devices or SPDs are used to protect sensitive load cell systems from damage caused by a variety of surges. For example, heavy power switching, lightning strikes, etc.

Introducing barriers into a weighing system results in almost all cases in temperature errors on offset and span. The errors are caused by a change in end-to-end resistance of the barrier, or by a change in the leakage current through the Zener diodes to ground.

There are three basic options to avoid errors caused by barriers. The first option is to keep the barriers at a

constant temperature. This is, for example, possible if they are installed in an air-conditioned process-control room. The second option is the use of sense lines in a balanced bridge circuit.

Sense lines control the operating voltage at the load cell(s) by either raising or dropping the excitation voltage, or by changing the amplifier rate of the indicator.

The third option is the use of temperature compensated and Weights and Measures approved barriers.

### 3. Summary

Load cells are offered in a wide variety of accuracy grades or classes. The performance of Weights and Measures approved load cells is traceable to OIML or NTEP standards. These standards are commonly used to compare and select load cells suitable for a particular application.

However, when used in practical applications, load cell performance also depends considerably on inherent design features such as sensitivity to loading conditions, dynamic temperature behavior, deflection, etc. Load cell manufacturers should be invited to provide information relating to such features which can assist installers optimize application performance.

By thus extending the relationship between load cell manufacturer and system designer, scale accuracy can be satisfied or enhanced. Alternatively, load cell dedicated scale design should allow total costs to be minimized.